

Pyrolysis-GC/MS System for Microplastics Analysis



Pyrolysis-GC/MS system tuned for Microplastics Analysis

Pyrolysis (Py)-GC/MS enables a direct analysis of solid/liquid samples to determine the formulation and chemical structures of sample. This technique can be applied to samples that are insoluble due to the large molecule (and/or cross-linked structure) and will not be changed without modification. The samples can be solid or liquid. This technique requires minimal sample preparation and only a small amount of sample for analysis. It even generates unique information about each polymer while other analytical techniques do not share this capability. Therefore, Py-GC/MS is a critical technique for plastics analysis.

We have developed a Py-GC/MS system optimized for the analysis of microplastics in environmental samples. With special data analysis software, even analysts with little experience in polymer analysis can easily utilize this technology in your laboratory. The analysis procedure, including identification and quantification, is automated, and results can be obtained in about 30 minutes per sample.

Py-GC/MS System Configuration

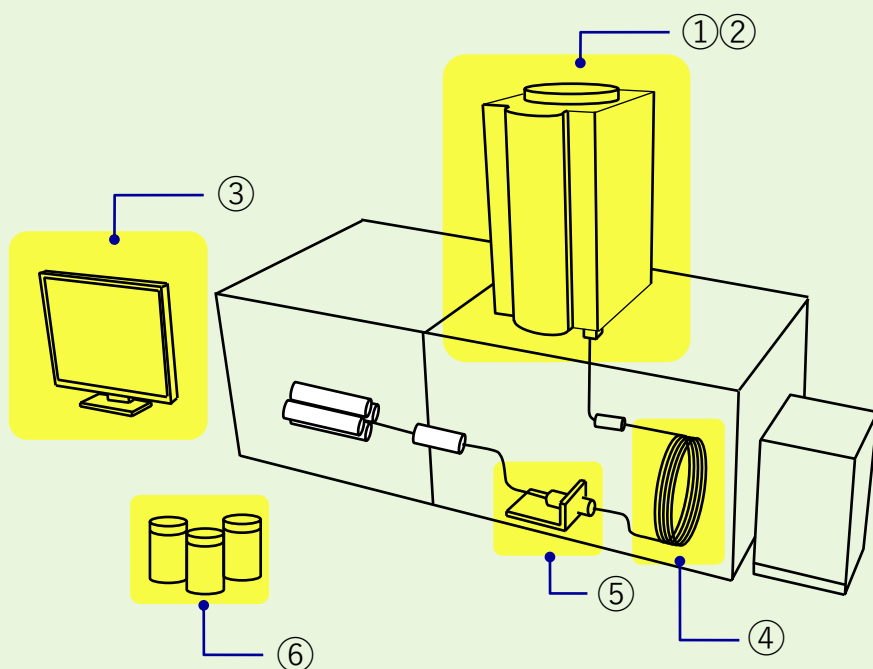

This system consists of a GC/MS system and accessory devices shown below.

① Multi-Shot Pyrolyzer (EGA/PY-3030D)

A vertical micro-furnace pyrolyzer based on a ceramic heater. A sample is heated in the furnace to form gaseous pyrolyzates, which are introduced into the GC.

② Auto-Shot Sampler (AS-1020E)

The Auto-Shot sampler automates a continuous series of analyses of up to 48 samples. This feature saves labor and improves reliability.

③ F-Search MPs*

*JPN patent 6683335

The unique search algorithm allows users with little experience in polymer analysis to obtain reliable microplastic identification and quantification results.

④ Ultra ALLOY® metal capillary column

These separation columns have superior inertness and resistance against bending, heating, and contamination due to the gradient-multi-layer deactivation treatment.

⑤ Vent-free GC/MS Adapter

This device saves time and increases productivity through fast switching between separation columns and/or an EGA tube without venting the MS detector.

⑥ Consumable Parts Kit

This kit includes consumable parts required for microplastics analysis.

Workflow for Microplastics analysis with our Py-GC/MS system

Step 1 Sampling and pretreatment

Microplastics are extracted from environmental samples by appropriate pretreatment and then homogenized using a grinder or mixer. The sample is then placed in a sample cup and weighed using a semi-micro balance.

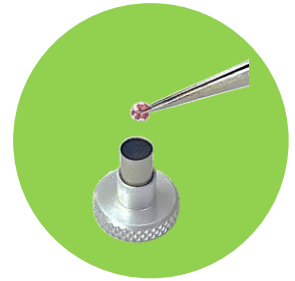

Step 2 Set of the sample cup on the Auto-Shot Sampler

The sample cups are placed onto the Auto-Shot Sampler. Up to 48 cups can be loaded each time.



Step 3 Pyrolysis of the sample

The sample is introduced into the pyrolyzer by the Auto-Shot Sampler and the sample is pyrolyzed. The plastics become pyrolysis products (pyrolyzates) and are introduced into the GC. On the other hand, the inorganics in the sample remain in the sample cup as residues.



Step 4 GC/MS Analysis

Pyrolyzates are separated on a GC column and detected by single Quadrupole mass spectrometer. The resulting pyrogram generally includes a peak for each pyrolyzate. The mass spectrum from each peak reflects the chemical structure of each pyrolyzate. Each polymer generates a unique set of pyrolyzates.

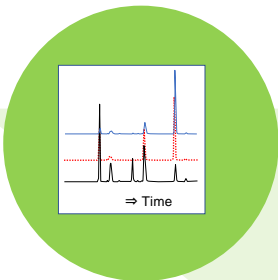

Step 5 Data Analysis

Data analysis and interpretation can be done using F-Search MPs. Calibration curves are created automatically based on the analytical results from the reference polymer mixture. Then F-Search MPs performs quantitative calculation automatically and results are reported for each sample.

Polymer	Prob. [%]
PE	99.9
PVC	95.9
SBR	10.5
PP	91.7
PS	99.6
PET	88.6
PMMA	99.9
PU	99.9
ABS	70.2
N66	96.1
N6	74.2
PC	70.7

Identification/Quantitation Analysis of Microplastics with F-Search MPs

The F-Search software results screen shown below identifies the detected plastic names, displays the match quality for the library search, and lists quantitation results. All information can be seen at a glance. The Mass Chromatogram and Mass Spectrum of a sample are shown side by side on the screen in comparison with the Mass Chromatogram and Mass Spectrum of the library reference.

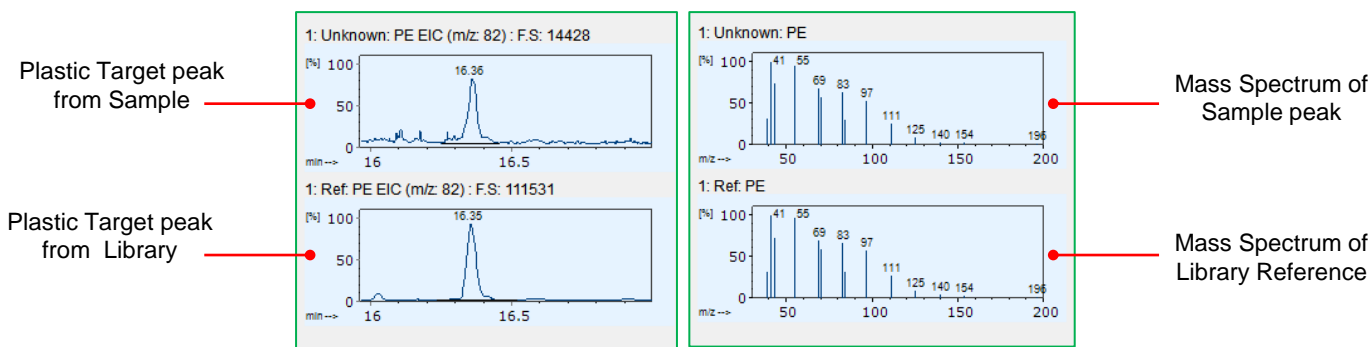
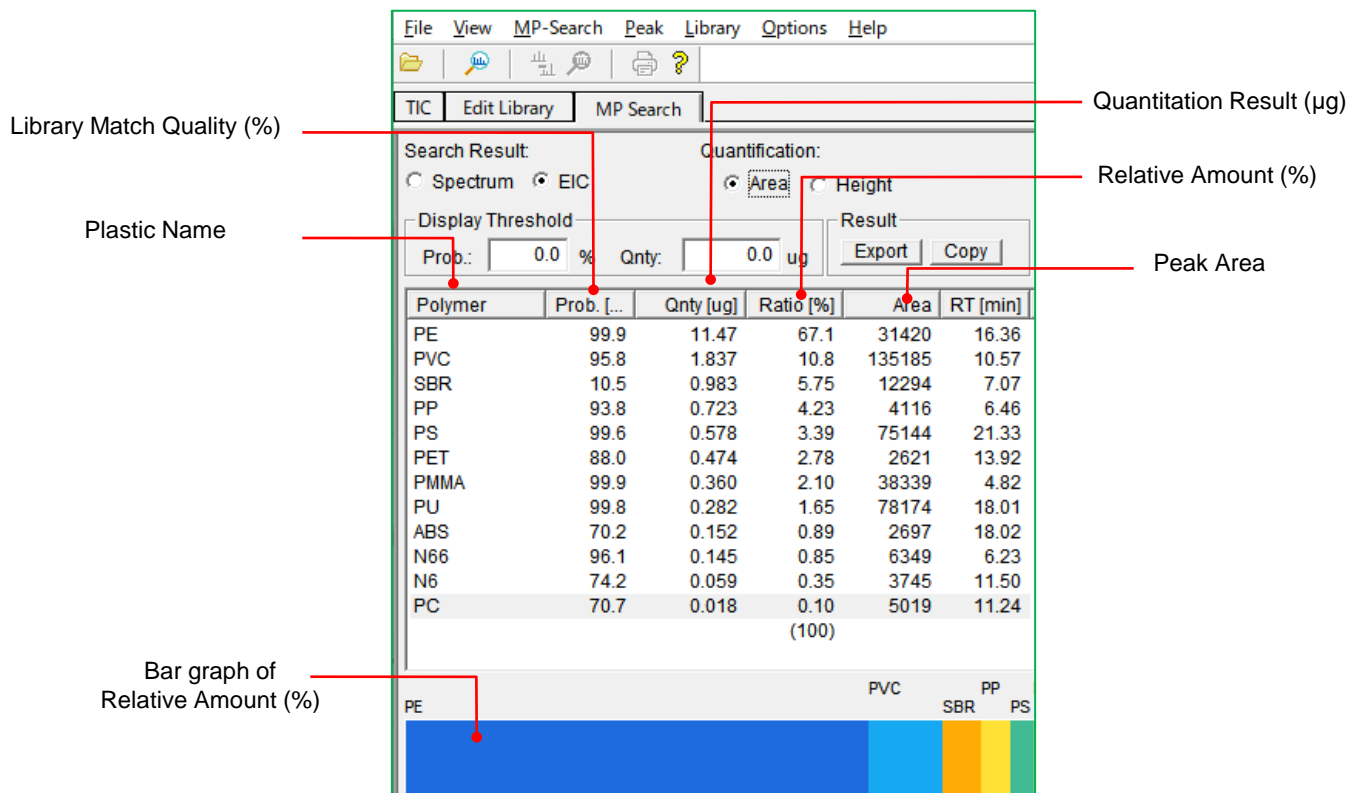

FRONTIER LABORATORIES LTD.

4-16-20 Saikon, Koriyama, Japan. 963-8862
 TEL: 81(24) 935-5100 FAX: 81(24) 935-5102
 www.frontier-lab.com